

Wärmepumpensysteme zur Dekarbonisierung von großen bestehenden Wohngebäuden

Pierre Holmüller

Universität de Genève

Integration von WP in bestehenden MF Gebäude

Knowledge / information gap:

- Mangel an standardisierten Schemas
- Mangel an robusten Kontrollstrategien (insbesondere für bivalente Systeme)
- Mangel an Fallstudien, Informationsblättern und Schulungsprogrammen

WP-Verkäufe in der Schweiz (2021) nach Leistung (kW)

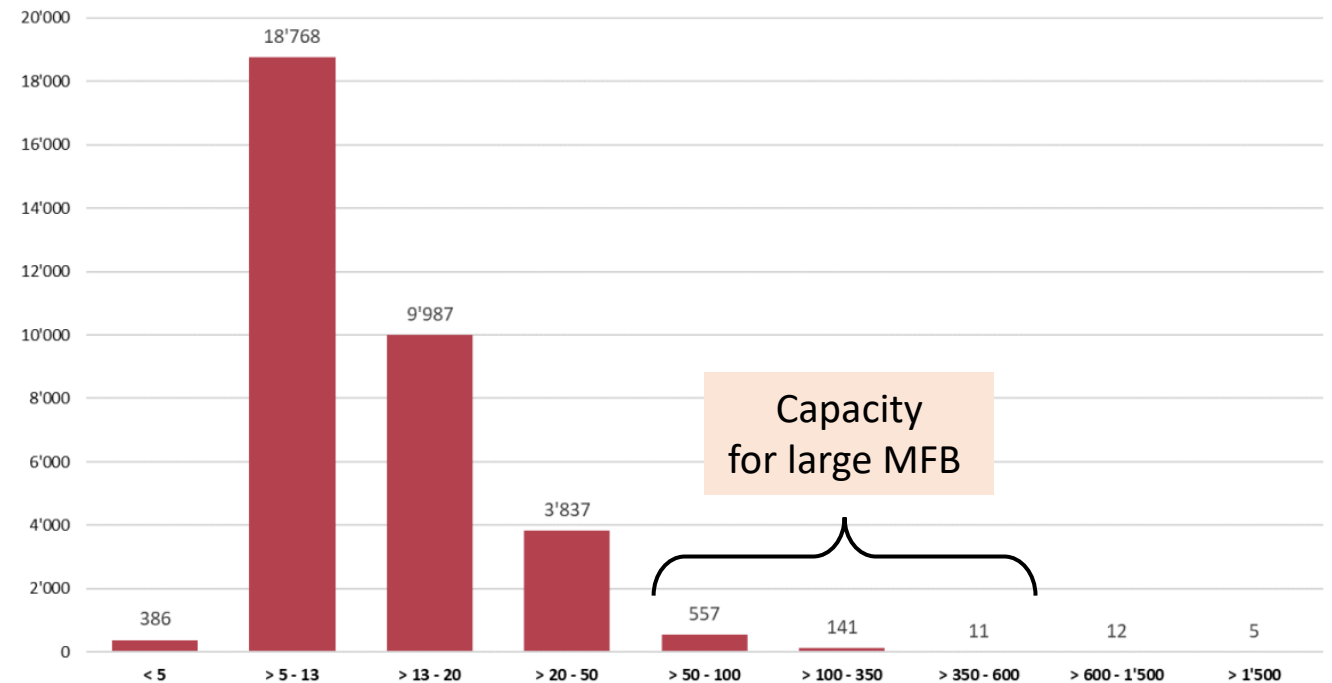

Source: Groupement professionnel Suisse pour les pompes à chaleur (GSP). Statistiques 2021

Fallstudien

- Datenblätter „Wärmepumpen für Mehrfamilienhäuser“
- Ergebnisse im realen Betrieb
- Hervorhebung von Punkten, die besondere Aufmerksamkeit erfordern
- Link zur detaillierten Studie

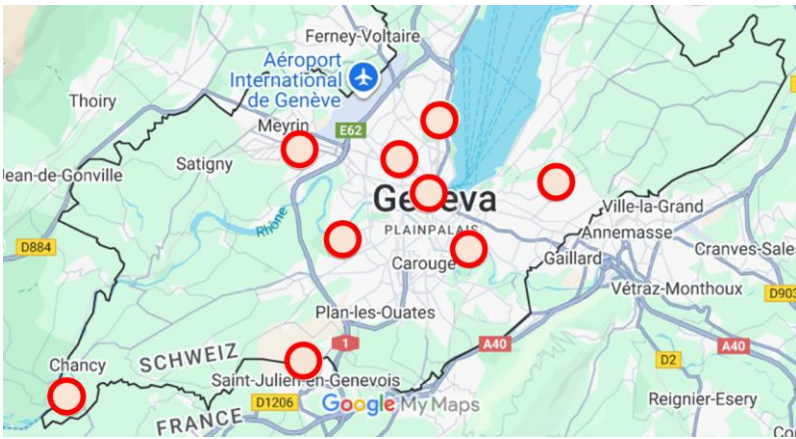

Source: Callegari, 2024:

<https://archive-ouverte.unige.ch/unige:180141>

<https://heatpumpingtechnologies.org/project62/case-studies-1/#Switzerland>

Case Studies
Heat Pumps in Multi Family Buildings

Soubeyran, Geneva – Switzerland

Heat pumps on exhaust air for space heating and domestic hot water in a very high performance multifamily building.

Key facts

Building	
Location	Geneva, Switzerland
Construction	2017
Type	Multifamily building
Heat distribution	Underfloor heating
Heated area	4'607 m ²
Level of insulation	High performance
Heat pump and source	
Number of HP	2
Installed capacity	44 kW _{th}
Operation mode	Bivalent
Heat source	Exhaust air
Backup heat source	Gas boiler (125 kW)
Heating system	
SH share, demand	66%, 35 kWh/m ² /y
Heating temperature	Max. 35°C at -5°C
Domestic hot water	
DHW share, demand	34%, 18 kWh/m ² /y
Type of system	Centralized
Max. temperature	60°C
Circulation system	Yes
Other information	
HP share, SPF	38%, measure: 3.28
Gas boiler share	62%
PV installation	30 kWp
Ventilation	Single-flow with heat recovery

Located in Geneva and built in 2017 by two housing cooperatives, the building under consideration has a 4607 m² heating reference area, which includes business premises on the ground floor and collective housing on the 5 upper floors. Its planned SH demand (18.6 kWh/m²/year) meets the cantonal “very high energy performance” standard.

Despite of the relative difference between planned and effective SH demand, which is a common situation, the SH demand of this building is close to the median of Geneva’s multifamily buildings constructed between 2011 and 2020.

In contrast, the DHW production turns out to be at the lower end of a benchmark on existing MFBs in Geneva.

HP on the roof & exhaust air vents in the back

Lessons learned

- Heat recovery in new MFB buildings, especially from ventilation, has the potential to cover a large part of their heat demand.
- While the use of HPs on exhaust air for the preheating of DHW is widespread, their use for combined DHW and SH production is much less known, results in a more complex system, for which standard solutions and hydraulic schemes need to be developed.

Delivered by: Energy systems group (University of Geneva)

<https://heatpumpingtechnologies.org/annex62/>

Case Studies
Heat Pumps in Multi Family Buildings

Soubeyran, Geneva – Switzerland: Technical details

The heat production system consists of two exhaust-air HPs (2 x 22 kW_{th}), which supply the underfloor SH system as well as DHW preheating, via common buffers. A condensing gas boiler (125 kW) ensures the complementary SH and DHW production. A 3-way valve allows to send the return flow from SH and DHW production directly to the gas boiler heat exchanger if its temperature is higher than that available in the accumulators, which happens when the gas boiler is in operation.

Heat recovery in new MFB buildings, especially from ventilation, has the potential to cover a large part of their heat demand. While the use of HPs on exhaust air for the preheating of DHW is widespread, their use for combined DHW and SH production is much less known.

In this case study, a HP system on exhaust air covers 38% of the heat production for SH and DHW of a new MFB, against a 61% projected value. Such discrepancy seems to be due to: i) a miss evaluation of the actual HP production / performance, as well as of the intrinsic HP temperature limitations in regard to DHW production; ii) a non-optimized hydraulic system, inducing unnecessary HP temperature degradation along the distribution chain.

While such solutions seem of interest for high energy performance buildings, and a fortiori when the DHW demand is lower than the potential heat recovery on exhaust air, it results in a more complex heat production and distribution system, for which standard solutions and hydraulic schemes need to be developed, and further monitoring in real condition of use needs to be done.

Final report: CALLEGARI, Simon Augustin, HOLLMULLER, Pierre (2023). Soubeyran 7 : pompes à chaleur sur air vicié avec valorisation pour le chauffage et l'eau chaude sanitaire, dans un immeuble d'habitat collectif de très haute performance énergétique à Genève. Url: <https://archive-ouverte.unige.ch/unige:169454>

Delivered by: Energy systems group (University of Geneva)

<https://heatpumpingtechnologies.org/annex62/>

P&D – Luft/Wasser WP Systeme für bestehende MF Häuser

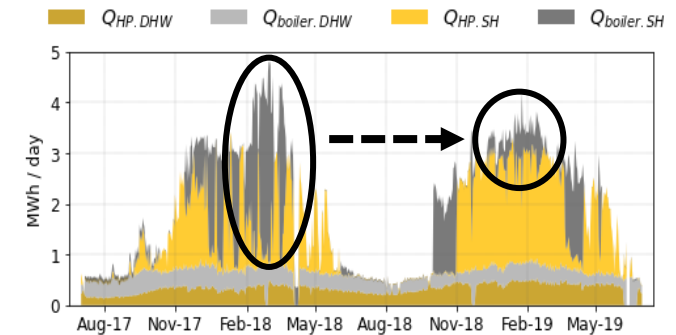
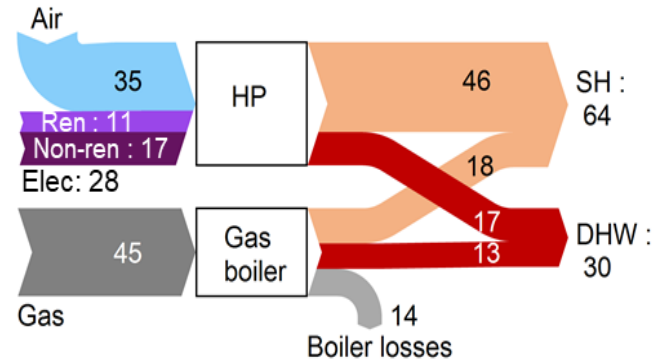
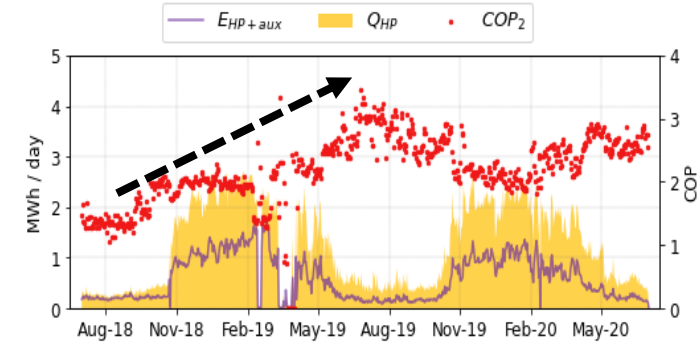
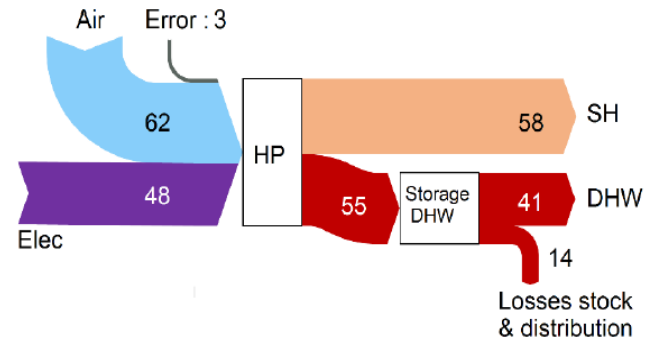

Montero et al. (2022). <https://archive-ouverte.unige.ch/unige:162052>

- ➔ CO₂-Einsparungen: 92 % (monovalent), 68 % (bivalent)
- ➔ Herausforderung: Optimierung der Hydraulik und Steuerung

WP – Integration und Dimensionierung

Hydronische Konfigurationen (monovalent oder bivalent)

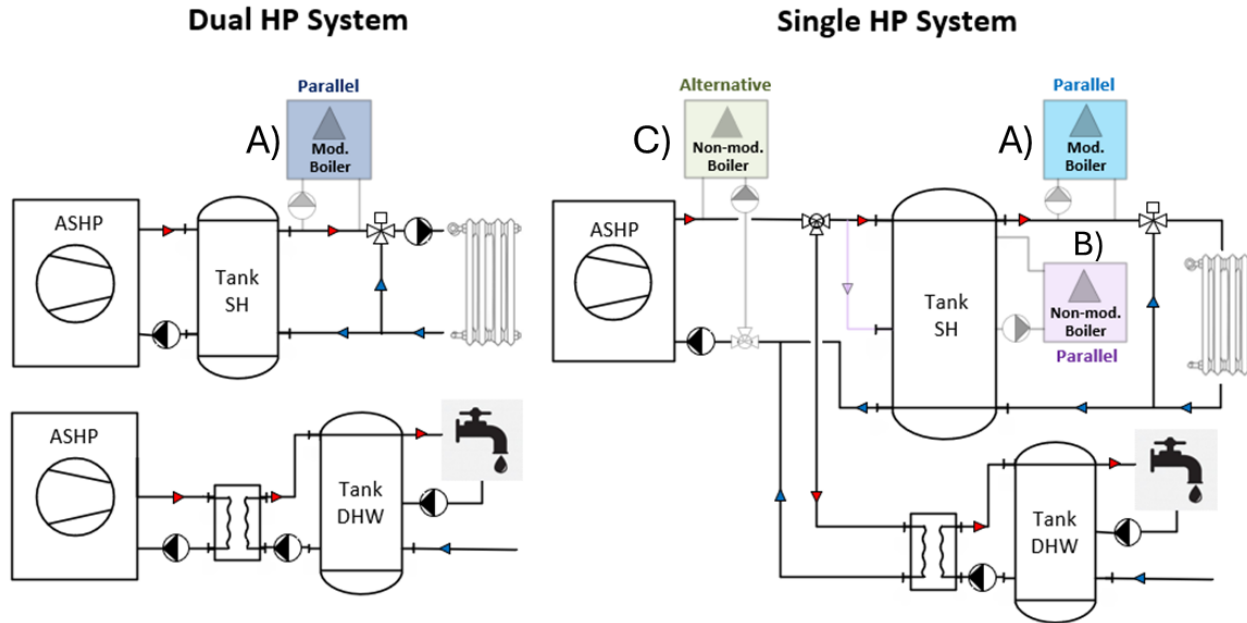

Possible hybrid configurations:

- A) Parallel with modulating boiler
- B) Parallel with non-modulating boiler
- C) Alternative with non-modulating boiler

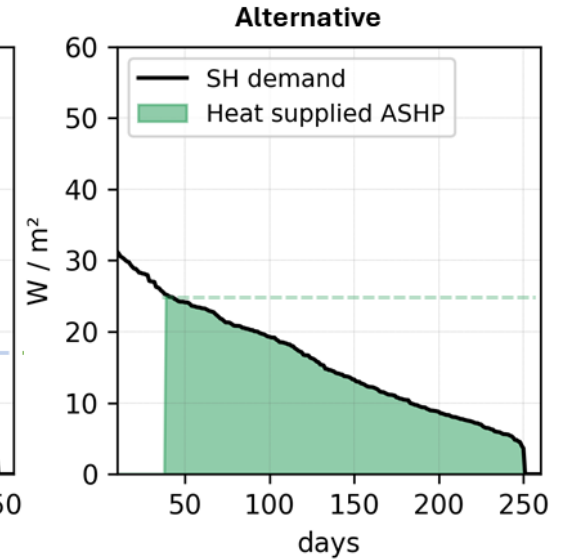
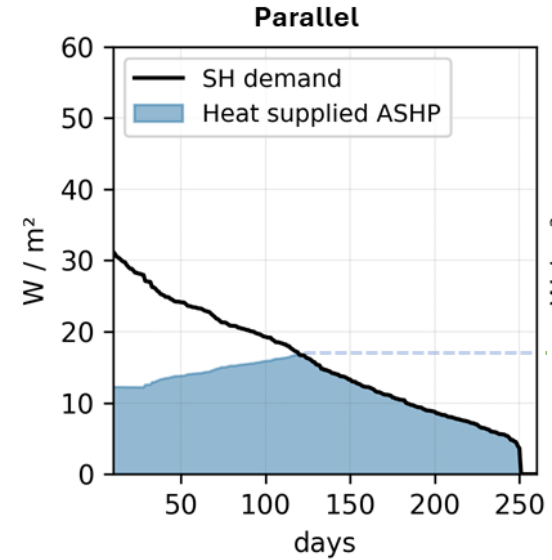

WP – Integration und Dimensionierung

Dimensionierung und Kosten

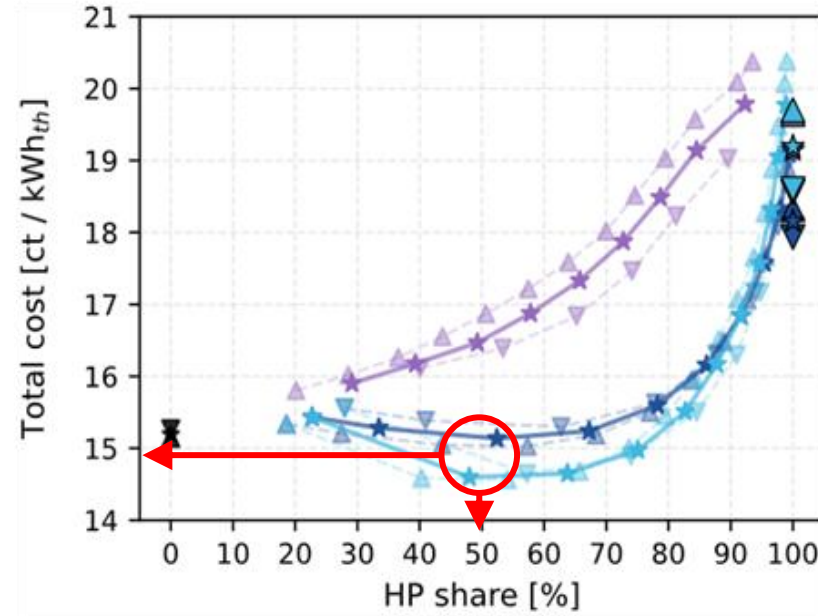
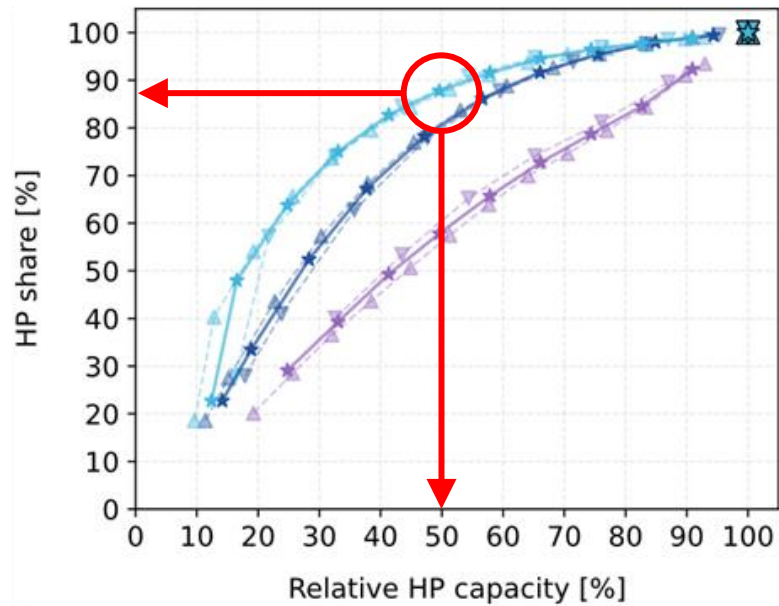

Montero et al.
(upcoming publication)

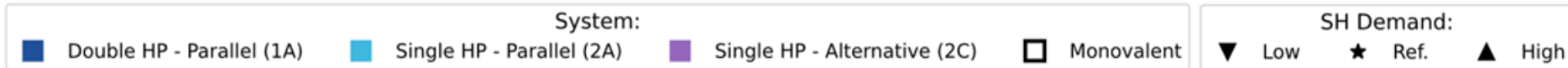

Bivalentes System (im Parallelbetrieb mit Gasheizkessel):

- HP-Anteil: 50 % Leistung (kW) => 80–90 % Wärmeproduktion (kWh)
- Kosten: 14 - 15 ct/kWh

Substitution der Wärmeerzeugung + Sanierung der Gebäudehülle

Kosten vs CO₂ (5 MF Typologien)

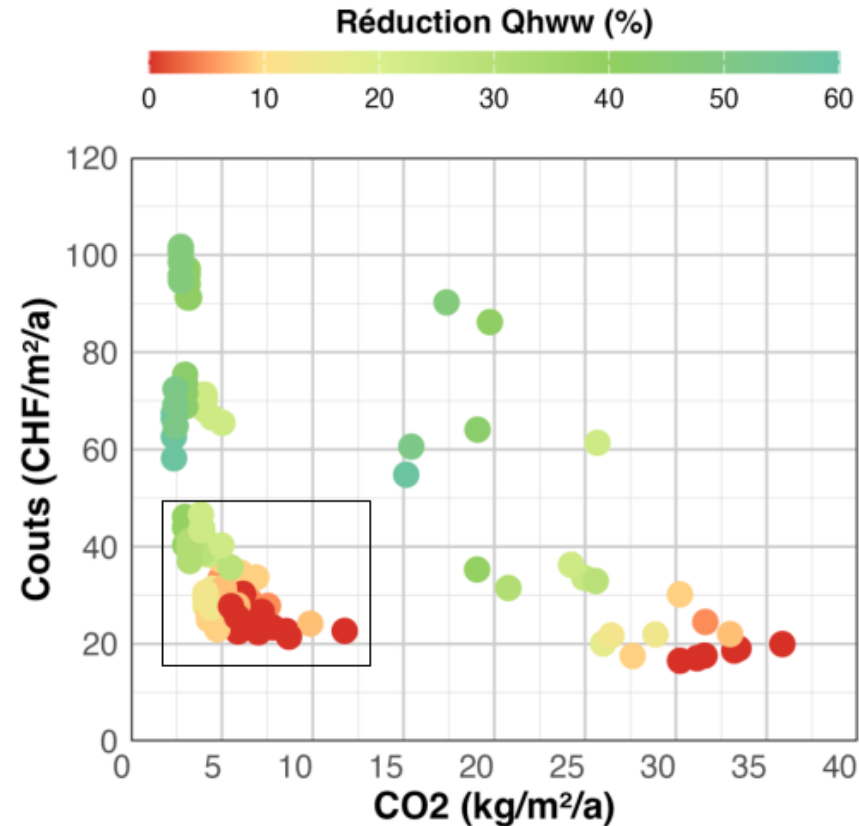
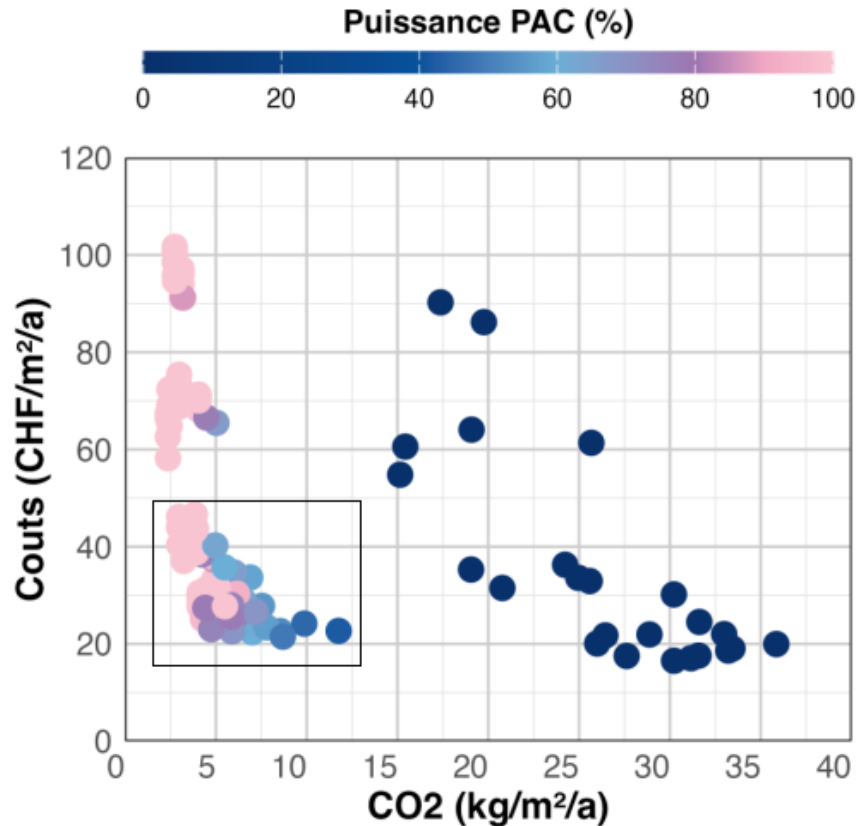

*El Hage et al.
(upcoming publication)*

Kost/CO₂ Optimum

➔ Teilsanierung + bivalentes WP-System

Take-home message

- Beispiele von Realisierungen (Infoblätter) + Dimensionierungsregeln
- Renovierung der Gebäudehülle und Umstellung auf Wärmepumpe können flexibel kombiniert werden
- Phasenplanung, je nach Möglichkeiten und Einschränkungen (Alterszustand, Finanzen, Architektur/Denkmalschutz, Stromkapazität usw.)

